

# SAFELINE Bridge parapet

H2 W2 Parapet

Installation manual



Installer:

**Vik:**  
6893 Vik i Sogn

**Tlf: +47 57 69 86 50**  
Faks: +47 57 69 86 60  
[firmapost@vikorsta.no](mailto:firmapost@vikorsta.no)

**Ørsta:**  
Skorgeura  
6150 Ørsta

**Tlf: +47 70 04 70 00**  
Faks: +47 70 04 70 04  
[firmapost@vikorsta.no](mailto:firmapost@vikorsta.no)



## Index

1. Important .....	3
2. Description .....	3
3. Level of performance .....	3
4. List of components .....	3
5. General dimensions, placement, heights and anchor bolts.....	3
6. Installing the SAFELINE H2 parapet.....	4
6.1 Installing the post.....	4
6.2 Installing the handrail.....	4
6.3 Connecting the handrails .....	5
6.4 Installing the front tube.....	5
6.5 Connecting the front tubes .....	5
6.6 Bolts/fasteners .....	5
7. Maintenance .....	5
7.1 Cleaning.....	5
8. Marking .....	5
9. Drawing .....	6

Copyright©, Vik Ørsta A/S

All right reserved. No part of this book may be reproduced or transmitted in any form or by any means, digital or permission in writing by Vik Ørsta A/S.

All statements and technical information are based on results obtained under typical conditions. It is the responsibility of the recipient to clarify with us that the information is appropriate for the specific use intended by the recipient. Please check with our Customer Service for further information.



## 1. Important

Proper installation and repair is essential to ensure the systems maximum performance.

## 2. Description

The SAFELINE parapet is a parapet system that is designed to enhance safety. The system has successfully been tested according to classes H2 described in EN 1317-2.

## 3. Level of performance

According to EN-1317

Post distance	Containment level	Working width [W]	Dynamic deflection	Impact severity level
2 m	H2	0,7m/W2	0,6 m	B

## 4. List of components

Art. no.	Pos. no (drw. no. T-0284-E)	Description	Detail drawing
511317	1	ANCHOR CONNECTION 140X140 M24X430 A4	T-0353
5131120	2	SAFELINE POST WITH FOOTPLATE	T-0286
5131200	4	HANDRAIL, TUBE Ø89 L= 6 M.	T-0260
5131201	5	HANDRAIL, TUBE Ø89 L= 4 M.	T-0309
5131210	6	FRONT TUBE, TUBE Ø89 L= 6 M.	T-0261
5131211	7	FRONT TUBE, TUBE Ø89 L= 4 M.	T-0313
5131300	8	CONNECTION TUBE Ø80, FOR GUARDRAIL	T-0247
5131301	9	CONNECTION TUBE Ø80, FOR HANDRAIL	T-0248
9270	10	PLASTIC BRACKETT FOR T-BOLT, GUARDRAIL-TUBE	T-0263
9271	11	PLASTIC BRACKETT FOR T-BOLT, HANDRAIL-TUBE	T-0264
4116044	12	T-BOLT M16X40 8.8VZN	T-0163
4916010	13	FLANGE NUT M16	T-0189
4116104	14	FLATHEAD BOLT M16X104 INCL. NUT AND WASHER	T-0419

## 5. General dimensions, placement, heights and anchor bolts.

The SAFELINE post has a maximum plastic moment capacity of 11,2 KNm. Recommended anchor bolts are: M24 A4 70 / M24 A4 80

<b>Art. No</b> <b>5131120</b>	<b>SAFELINE parapet post</b>	
----------------------------------	------------------------------	--

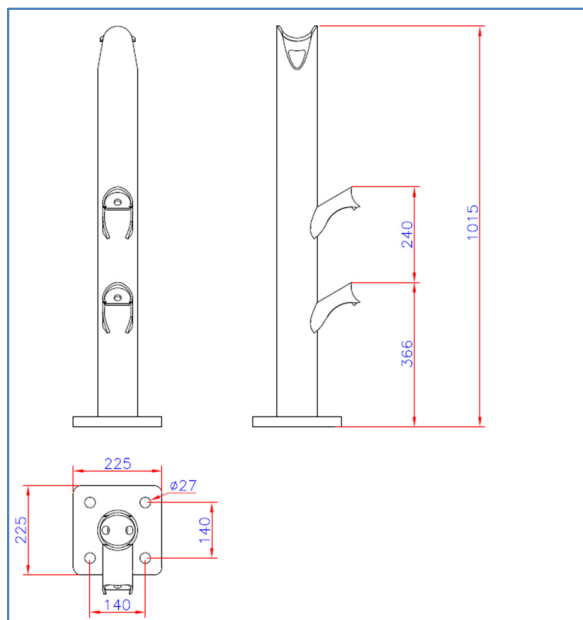

## 6. Installing the SAFELINE H2 parapet

### 6.1 Installing the post

The posts should be installed with a nut and washer on both sides of the base plate on each anchor bolt, see Pos 1 on drw. no. T-0284-E, Detail 1. The height and alignment of the installed parapet can then be adjusted by altering the heights of these nuts.

### 6.2 Installing the handrail

The handrails have rectangular holes to preassemble the T-bolts through the plastic bracket before connecting the handrail to the post. See pos 11 and 12 on drw. no. T-0284-E, detail 2.

This is done by:

1. Assemble the T-bolt and plastic bracket together by pressing the threads of the T-bolt through the plastic bracket.
2. Insert the head of the T-bolt in to the rectangular hole of the tube and turn the bolt 90 degrees.
3. Pull the T-bolt out so that the wings of the plastic bracket grip the head of the bolt so it can't turn.

The tube can then be lifted on to the post, inserting the T-bolts through the holes on the top of the post.



### **6.3 Connecting the handrails**

The handrail is connected using the handrail connecting tube and 8 pcs. M16x104 bolts, washers and nuts. See Pos 8 and 14 on drw. no. T-0284-E, detail 4.

### **6.4 Installing the front tube**

The front tubes have rectangular holes to preassemble the T-bolts through the plastic bracet before connecting the tube to the post. See pos 10 and 12 on drw. no. T-0284-E, detail 3.

This is done the same way as for the handrail tube.

The tube can then be lifted on to the post, inserting the T-bolts through the holes in the front shield.

### **6.5 Connecting the front tubes**

The front tubes are connected using the front tube connecting tube and 6 pcs. M16x104 bolts, washers and nuts. See Pos 9 and 14 on drw. no. T-0284-E, detail 5.

### **6.6 Bolts/fasteners**

Please check that all bolts/fasteners are placed correctly and all bolts-washer-nuts-connections are normally/properly fastened/tightened.

## **7. Maintenance**

There are no general inspection intervals for this parapet itself. Inspection intervals have to be determined based on local factors such as volume of traffic, risk of damage, climate etc.

The parapet should be inspected regularly and if displaced or damaged, it should be adjusted and repaired.

All damaged profiles should be replaced with new when repaired.

### **7.1 Cleaning**

Cleaning can be done with water and any type of pH neutral detergent.

## **8. Marking**

If everything is done and installed according to this installation manual, the guardrail can be marked with the CE-mark. This mark shall be placed at the end (the starting end) of the installed guardrail.

9. Drawing

The drawing illustrates the installation of the SAFELINE parapet. It includes a side view showing the parapet structure with dimensions of 2000 mm between posts and a total height of 1200 ± 20 mm. Details 1, 2, and 3 provide close-up views of the handrail and guardrail connections. A parts list table is provided below the drawing.

Art. no.	Pos. no.	Description	Detail drw.
4116104	14	FLATHEAD BOLT M16X104 INCL. NUT AND WASHER	T-0419
4916010	13	FLANGE NUT M16	T-0189
4116044	12	T-BOLT M16X40 8.8VZN	T-0163
9271	11	PLASTIC BRACKET FOR T-BOLT, HANDRAIL-TUBE	T-0264
9270	10	PLASTIC BRACKET FOR T-BOLT, GUARDRAIL-TUBE	T-0263
5131301	9	CONNECTION TUBE Ø80, HANDRAIL	T-0248
5131300	8	CONNECTION TUBE Ø80, GUARDRAIL	T-0247
5131211	7	GUARDRAIL, TUBE Ø89 L= 4 M.	T-0313
5131210	6	GUARDRAIL, TUBE Ø89 L= 6 M.	T-0261
5131201	5	HANDRAIL, TUBE Ø89 L= 4 M.	T-0309
5131200	4	HANDRAIL, TUBE Ø89 L= 6 M.	T-0260
5131110	3	SAFELINE POST WITH FOOTPLATE	T-0256
5131120	2	SAFELINE POST WITH FOOTPLATE	T-0286
511317	1	ANCHOR CONNECTION 140X140M24X430.4.4	T-0353

